

# RIDE THE BLUE WAVE!

Wash with Confidence with Blue Wave Laundry Equipment



## UVH SERIES

### FEATURES AND BENEFITS:

- WINDOWS BASED, 7", TOUCH SCREEN CONTROLLER
- LG. LOADING /UNLOADING DOOR
- DISINFECTION LEVEL UV ON-BOARD
- S.S . FRONT, SIDE, AND TOP PANELS FOR ELEGANT LOOK
- 30 FULLY PROGRAMMABLE CYCLES
- 3 YEAR WARRANTY
- EFFICIENT, TEMP CONTROLLED, WATER MIXING VALVES
- WORLD CLASS COMPONENTS
- HEAVY DUTY SUSPENSION
- 300 G-FORCE EXTRACT
- NO SPECIAL FLOORING REQUIRED



SPECIFICATIONS	UNIT	UVH25	UVH35	UVH45	UVH60
Loading Capacity	lbs.	25	35	45	60
Volume	Ltr.	3.85	4.77	6.32	8.83
Diameter	in.	25.6	25.6	25.6	29.5
Depth	in.	13.4	16.5	21.4	21.7
Washing Speed	rpm	32	32	32	32
Mid Extract Speed	rpm	420	420	420	420
High Extract Speed	rpm	900	900	900	900
G-Force		300	300	300	300
Center of door to floor	in.	25.85	25.85	31.4	31.4
Bottom of door to floor	in.	16.8	16.8	21.3	21.3
Motor Pwr	kw	1.5	1.85	3	3.7
Circuit Protection	Amp	10	10	20	20
Electrical	VAC	220/60/1	220/60/1	220/60/1	220/60/1
Water Inlet	in.	3/4	3/4	3/4	3/4
Drain Diameter	in.	3	3	3	3
<b>Dimensions</b>					
Length	in.	32.3	35.4	35.4	43.6
Width	in.	33.1	33.1	38	37
Height	in.	51.5	51.5	56	57
Net Weight	lbs.	600	618	763	816

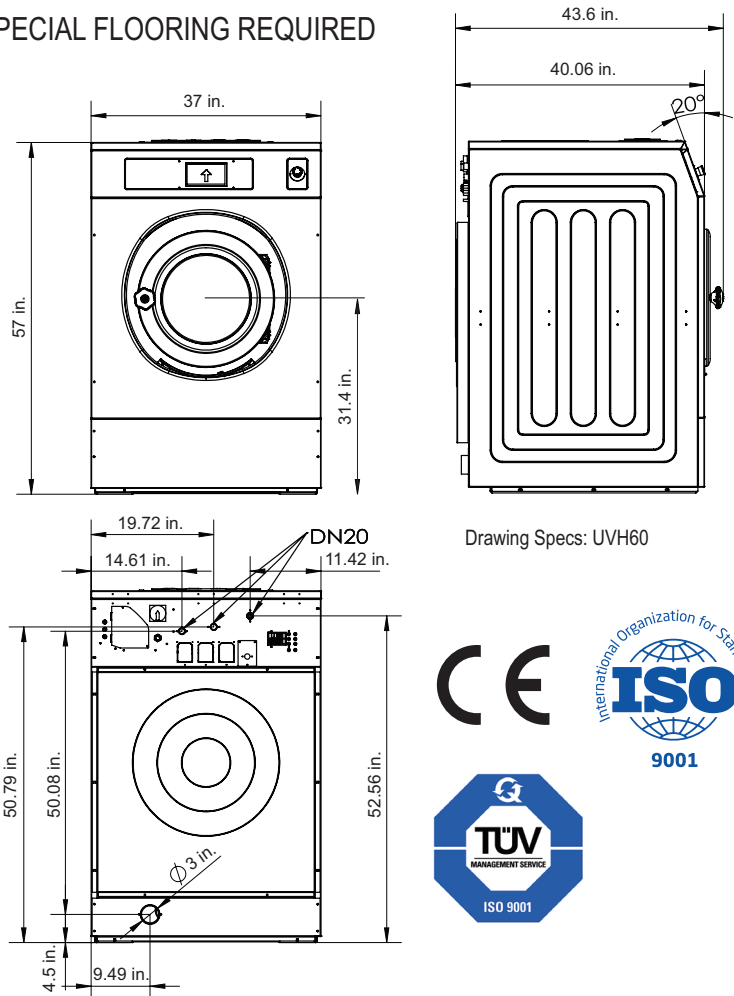

**LaundriTek Inc.**  
 4855 W McDowell Road • Suite 140B  
 Phoenix, AZ 85035  
 602-449-8964

**LAUNDRI**TEK

**LaundriTek.com**

UVH SERIES/REV0322